

Y2SS3-S

Fully Closed Loop Stepper Driver

User Manual



Guangdong Kaifull Electronics Technology Co., Ltd.



全研科技有限公司
CHIUAN YAN TECHNOLOGY CO., LTD.



Contents

1	FOREWORD	3
2	INSTALLATION DIMENSIONS	3
3	TECHNICAL SPECIFICATIONS	4
4	WIRING	5
4.1	REAL PRODUCT PHOTO.....	5
4.2	WIRING METHOD.....	5
4.2.1	POWER CONNECTION.....	6
4.2.2	MOTOR CONNECTION.....	8
4.2.3	ENCODER CONNECTION.....	9
4.2.4	DIGITAL SIGNAL CONNECTION.....	10
5	SOFTWARE SETTING	15
5.1	DRIVER CONNECTION.....	15
5.1.1	CONNECTING WIRE PREPARATION.....	15
5.1.2	DRIVER CONNECTION.....	16
5.2	DRIVER PARAMETERS MODIFICATION.....	19
5.2.1	CONTROL MODE.....	19
5.2.2	CURRENT SETTING.....	20
5.2.3	SUBDIVISION SETTING.....	21
5.2.4	ENCODER RESOLUTION SETTING.....	22
5.3	PARAMETERS SAVING.....	23
5.4	SAVING/OPENING PARAMETER FILE.....	24
5.5	FIRMWARE UPDATE.....	25
6	ALARM CODE	26
7	CONTACT KAIFULL	错误! 未定义书签。



1 Foreword

- Thank you for choosing Kaifull's product.
- This manual describes the use methods and safety precautions of the product.
- Please read this user manual carefully and use this product correctly and safely.
- After reading, please save it at a suitable place for easy access at any time.
- For technical support, please dial 400-960-1069 or +86-769-23033384.

2 Installation Dimensions

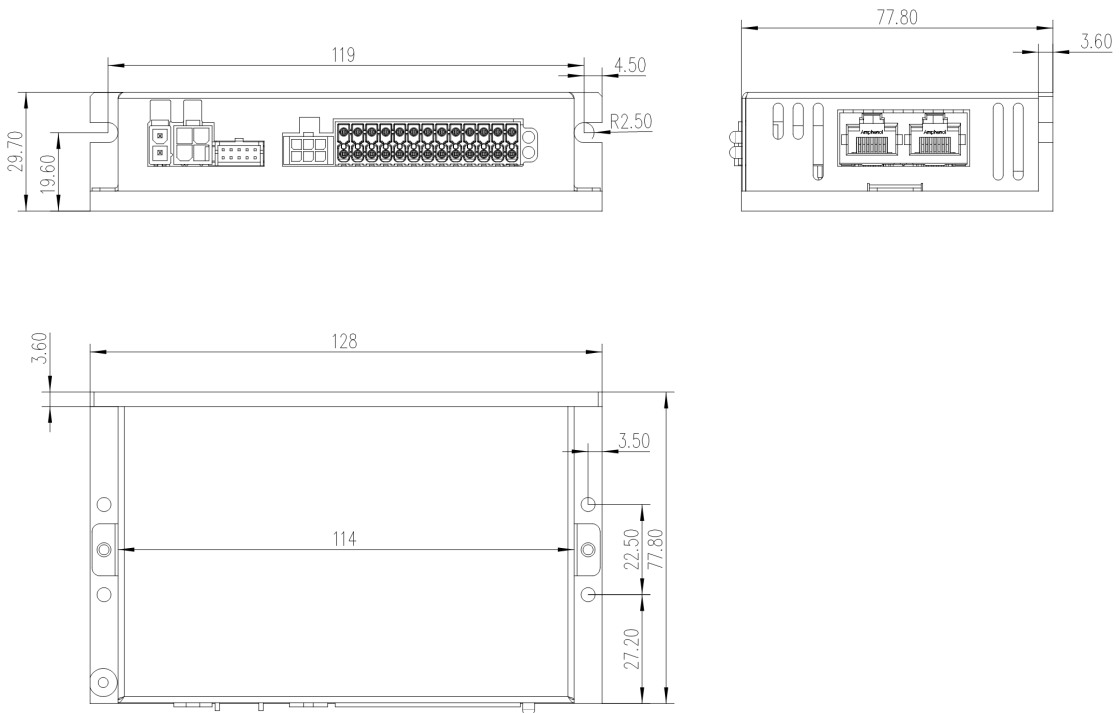

3 Technical Specifications

Technical Specifications		
Dimensions and specifications	128 × 77.8 × 29.7 cm	
Input power	DC: 24-75V or AC: 18-50V	
Current output	0.1-7A (peak)	
Adaptive motor	Two-phase closed-loop stepper motors of size 86 and below	
Open loop/closed-loop control	Fully closed loop control	
Encoder interface	Supports up to 5000-line incremental encoders (20000 pulses/revolution)	
Control mode	Pulse control (pulse+direction, CW/CCW)	
Communication interface	RJ45 network port	Connect to PC for parameter settings, status monitoring, etc.
Control signal	Digital input signal	Two circuits of high-speed pulse input and two circuits of digital signal input; equipped with opto-isolator, supports differential/single end; supports 5-24VDC at the high level
	Digital output signal	A/B/Z encoder differential signal output
		Two circuits of opto-isolator output signal; supports differential/single end; maximum output 100mA@30V
Recommended service environment	Temperature	0 ~ +55 °C
	Humidity	0~ 90%RH below
	Altitude	1000 m below
	environment	No corrosive gases or dust. The product shall not come in contact with water and oil.
Dielectric strength	AC1.5KV between ground wires, capable of withstanding voltage for 1 minute	
Protection grade	IP20	
Weight	0.3KG	

4 Wiring

4.1 Real product photo

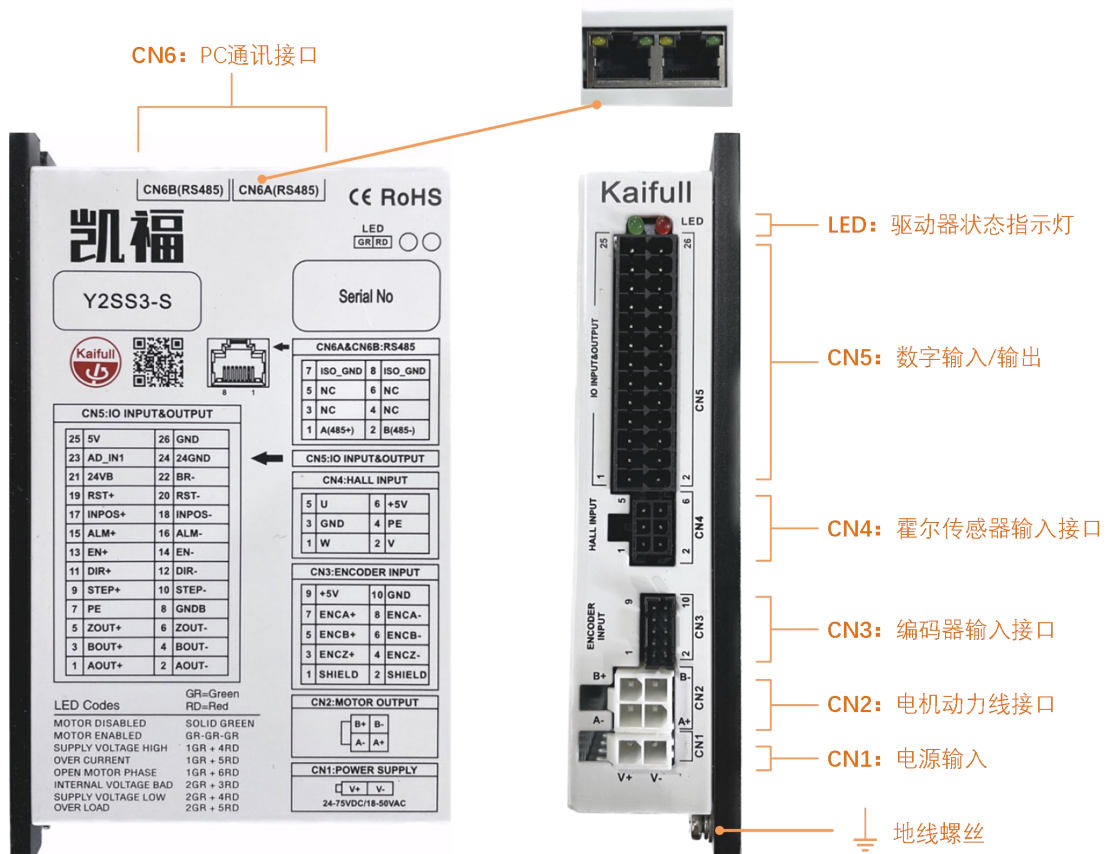

4.2 Wiring method

Note: The Hall sensor and analog input characteristics have not been enabled yet, and the relevant wiring methods will not be described here

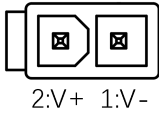

4.2.1 Power Connection

CN1: Power port (24-75VDC or 18-50VAC)		
CN1.1	V-	 2:V+ 1:V-
CN1.2	V+	

The Y2SS3-S driver product comes with a 1m-long power cord. When you connect the power supply, connect the red wire of this power cord to the switch power supply V+ and the black wire to V -.

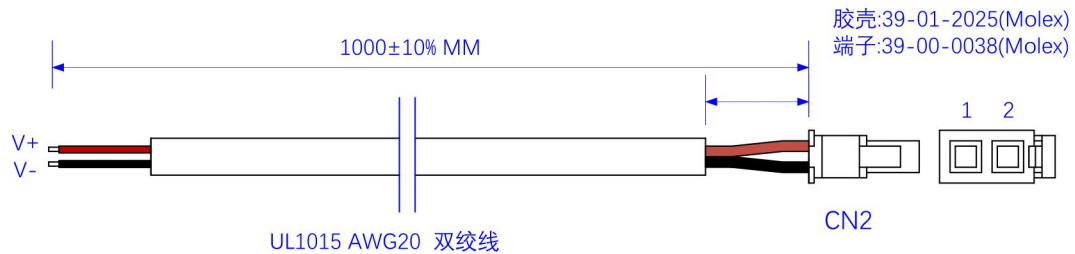

➤ Selecting the appropriate power supply:

The following are recommendations for selecting the power supply when using different motors:

Motor flange (MM)	Supply voltage	Supply current
20/35	24V	≥1.0A
42	24V	≥2.0A
57/60	24-36V	≥4.5A
86	36-48V	≥6A



- Be careful not to connect the power supply reversely, as it may cause damage to the drive and result in no warranty coverage
- When the motor 57 and above is used and the motor is operating at a high speed, it will generate a large reverse electromotive force. At this time, use a higher-voltage power supply to improve the high-speed performance of the motor.

4.2.2 Motor Connection

CN2: Motor port				
CN2.1	B-	CN2.2	A+	
CN2.3	B+	CN2.4	A-	

The motor interface of the Y2SS3-S driver matches the power wire interface of the Kaifull closed-loop motor. When in use, the motor power wire can be directly connected to the driver or connected to the driver through the motor extension wire (optional).

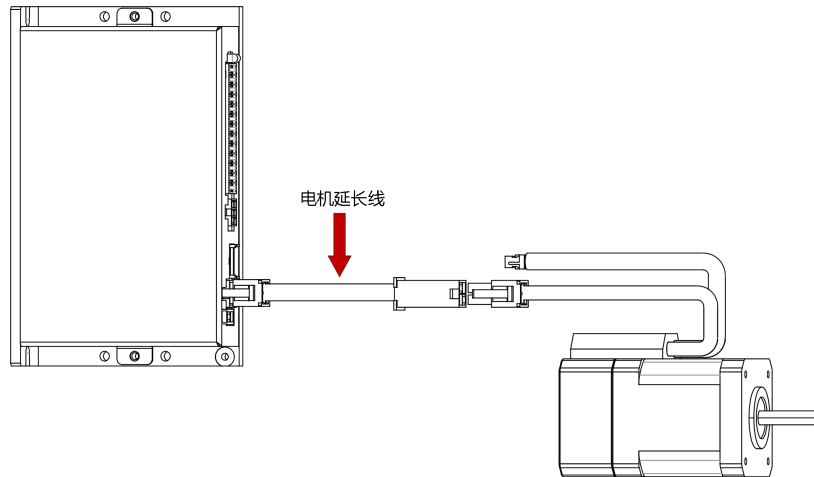

4.2.3 Encoder Connection

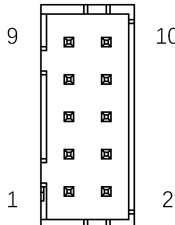
CN3: Encoder input port				
CN3.1	Cable shielded wire	CN3.2	Cable shielded wire	
CN3.3	ENCZ+	CN3.4	ENCZ-	
CN3.5	ENCB+	CN3.6	ENCB-	
CN3.7	ENCA+	CN3.8	ENCA-	
CN3.9	+5V output	CN3.10	GND	

The encoder interface of the Y2SS3-S driver matches the power wire interface of the Kaifull closed-loop motor. When in use, the motor encoder wire can be directly connected to the driver or connected to the driver through the motor encoder extension wire (optional).

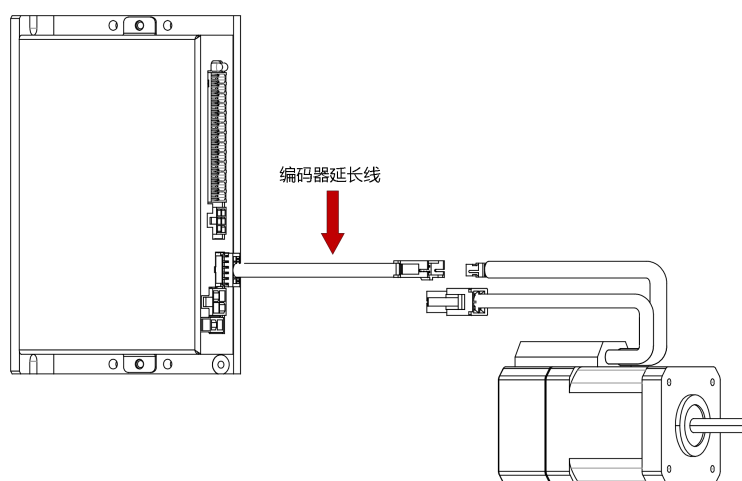

➤ Accessory Information

Type	Model	Length
Motor extension wire	2103-100	1 m
	2103-300	3 m
	2103-500	5 m
Encoder extension wire	E208-100	1 m
	E208-300	3 m
	E208-500	5 m

4.2.4 Digital Signal Connection

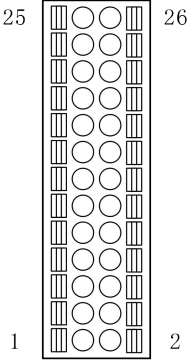
CN5: Digital signal port							
Pin	Signal	Description			Pin	Signal	Description
CN5.1	AOUT+	Encoder output A+			CN5.14	EN-	Enabling signal-
CN5.2	AOUT-	Encoder output A-			CN5.15	ALM+	Alarm signal+
CN5.3	BOUT+	Encoder output B+			CN5.16	ALM-	Alarm signal-
CN5.4	BOUT-	Encoder output B-			CN5.17	INPOS+	In-place signal+
CN5.5	ZOUT+	Encoder output Z+			CN5.18	INPOS-	In-place signal-
CN5.6	ZOUT-	Encoder output Z-			CN5.19	RST+	Alarm reset+
CN5.7	PE	Ground wire			CN5.20	RST-	Alarm reset-
CN5.8	GNDB	Encoder ground wire			CN5.21	24VB	Brake power supply 24V
CN5.9	STEP+	Pulse signal+			CN5.22	BR-	Brake output -
CN5.10	STEP-	Pulse signal-			CN5.23	AD_IN1	Analog input 1
CN5.11	DIR+	Direction signal +			CN5.24	24GND	Brake power supply 0V
CN5.12	DIR-	Direction signal -			CN5.25	Analog input special interface	Potentiometer power supply+5V
CN5.13	EN+	Enabling signal+			CN5.26		Potentiometer power supply 0V

■ **When the control signal is a collector open circuit**

- NPN type connection method

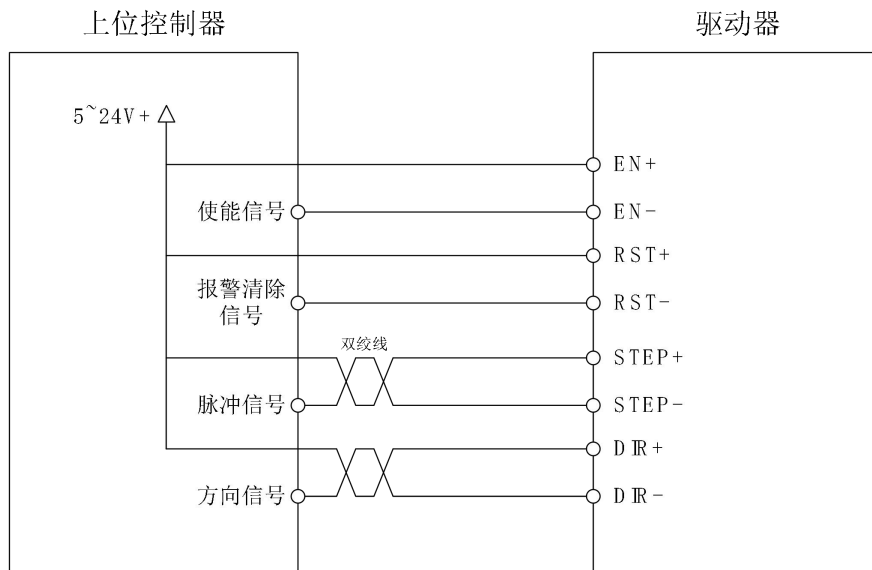

- PNP type connection method

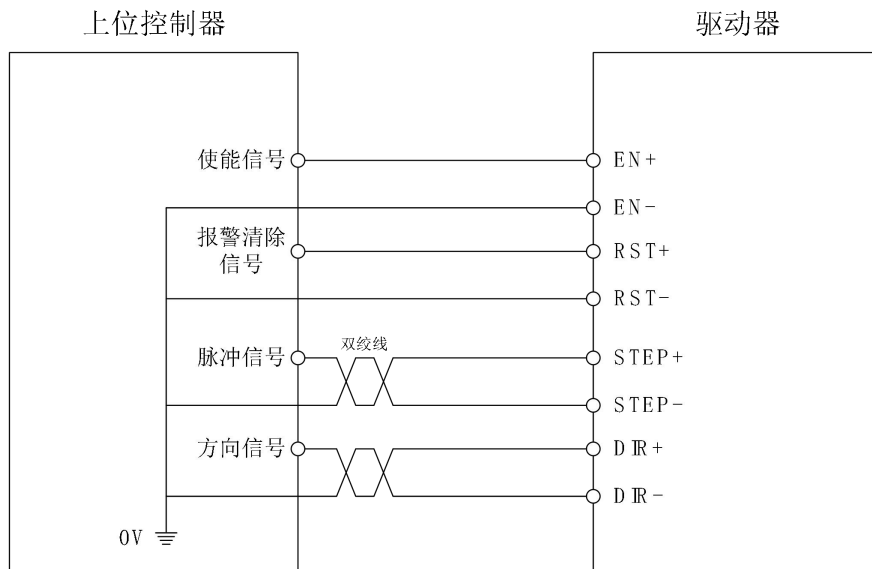

■ **When the pulse signal is a differential signal**

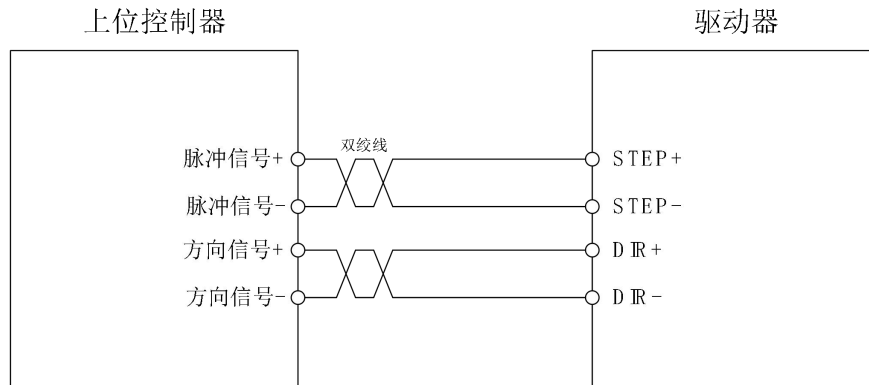

■ **Digital Output Connection**

The alarm output interface of Y5SD2 is an open drain output, and can output different levels according to different wiring methods.

Status of the Y2SS3-S output port during operation:

ALM	When the drive is normal, it is OFF; when an alarm occurs, it is ON
INPOS	OFF when the motor is in motion, ON when the motor is stationary

• **NPN type connection method**

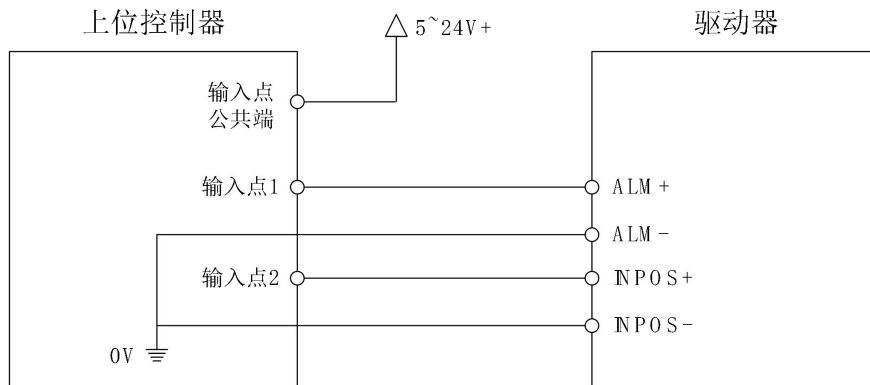

- PNP type connection method

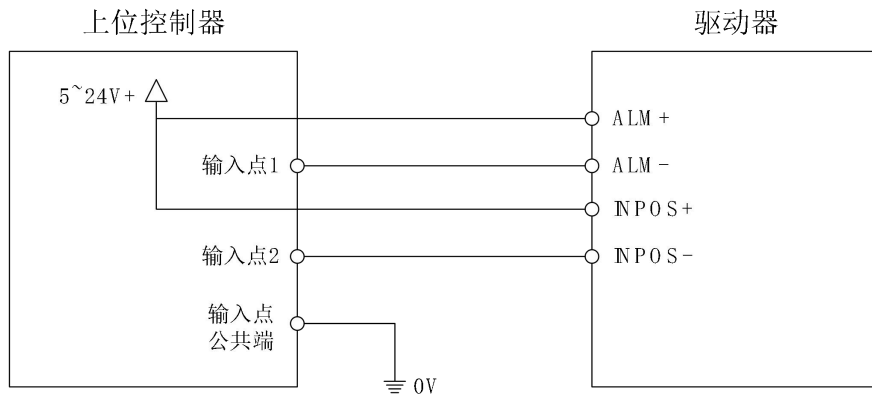

■ Encoder Output Connection

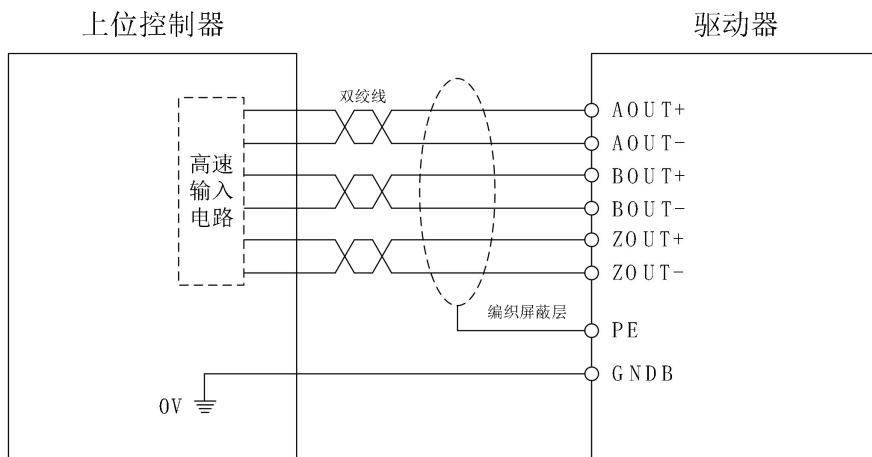

■ Power-off Brake Connection

A power brake is an electromagnetic brake device installed at the tail end of a stepper motor. A stepper motor with a brake is commonly used on mechanisms that move vertically. It can provide holding force in the event of sudden loss of equipment power to prevent the vertical mechanism from falling due to its own gravity.

An automatic control brake function is built in the Y2SS3-S driver, and it can turn on the brake at the moment when the motor is enabled, and turn off the brake at the moment when the driver gives an error alarm and the motor is disabled, and users do not need to manually control it.

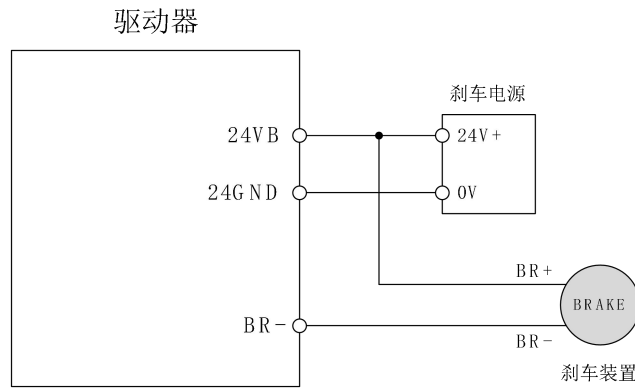

- Users need to prepare a 24V power supply to power "24VB" and "24GND"
- The maximum output of the brake output port is 500mA@30V , and it can drive the brake device without being connected to a relay
- It is recommended to use cables of 0.3mm² and above

■ Communication Port Connection

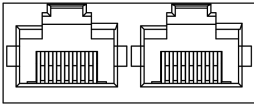
CN6: Communication Port			
CN6A	RJ45 Network port	 <p>CN 6A CN 6B</p>	<p>The CN6 interface is an RS845 interface used to connect to the Kaifull PC software for setting driver parameters and monitoring status, etc. You may select to connect either of the two interfaces during connection.</p>
CN6B	RJ45 Network port		

Y2SS3-S has two RJ45 network ports for connecting PC software to set parameters and monitor status. The communication protocol is MODBUS RTU 485.

Such two network ports have a daisy chain topology, and you may select either one during connection.

Network port pin	Definition
1	485+
2	485-

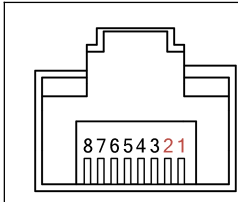

5 Software Setting

Y2SS3-S sets all parameters including current, subdivision and encoder resolution of the driver through software.

5.1 Driver Connection

5.1.1 Connecting Wire Preparation

1. USB to 485 connection wire; 2. DB9 to screw connection terminal; 3. Cut network cable

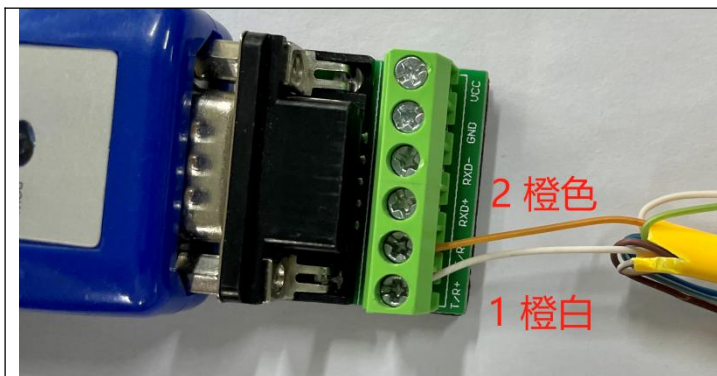
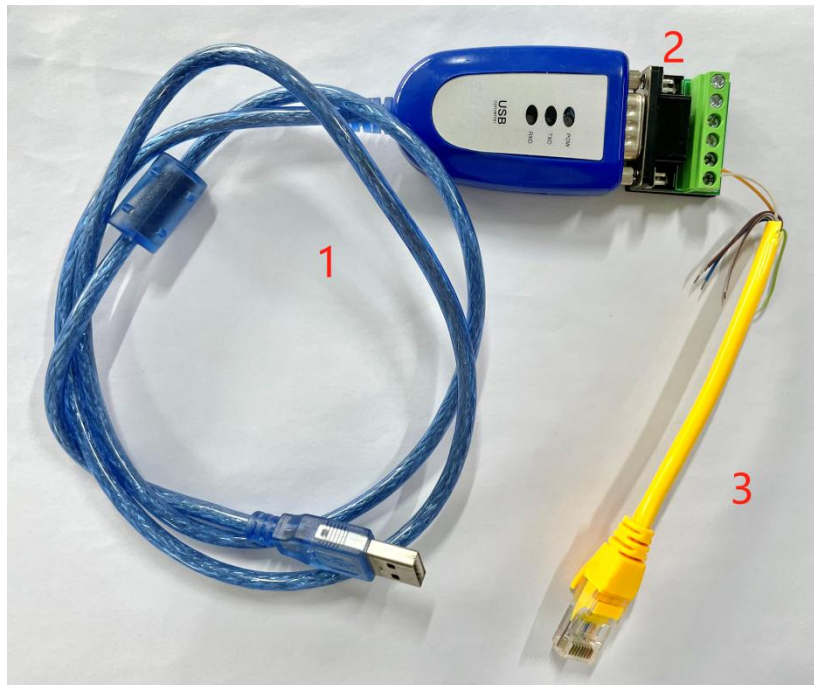

Network cable pin	Network cable color	Driver
1	Orange white	485+
2	Orange	485-

5.1.2 Driver Connection

1. Insert the prepared network cable into the driver CB6A or CN6B



2. Start the Kaifull software



Software interface:



3. Select the correct COM port

Select the corresponding COM port connection on the Kaifu software by viewing the computer device administrator

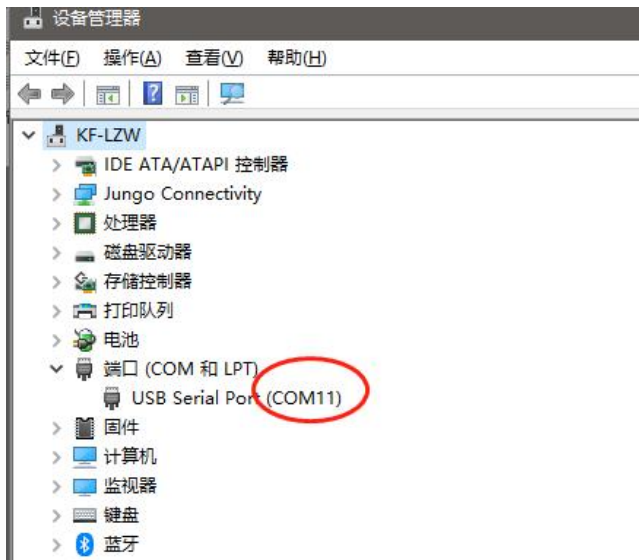

4. Select the driver & upload the parameters

Click "Connect"



You may upload the parameters after successful connection



5.2 Driver Parameters Modification

5.2.1 Control Mode

Y2SS3-S is compatible with two pulse types: "pulse+direction" and "double pulse". Please select the appropriate pulse type according to your specific application requirements.

2. 控制设置

编码器电子齿轮比	4000 (200-51200)	载入	读取	误差控制增益	13 (1-100)	载入	读取
细分电子齿轮比	4000 (200-51200)	载入	读取	到位输出最小误差	24 (2-100)	载入	读取
平滑滤波	100 (1-1500)	载入	读取	控制方式	闭环	载入	读取
运动过程允许最大误差	180 (1-360)	载入	读取	控制模式	单脉冲模式	载入	读取
静态误差时间报警使能	不使能	载入	读取	给定第1段转	双脉冲模式	载入	读取
静态误差偏离最小误差允许时间	0.5 s	载入	读取	给定第2段转	自测试模式	载入	读取
静态误差速度阈值	10 (1-50)	载入	读取	加速度	30 (rps/s/s)	载入	读取
静态误差阈值	65 (20-10000)	载入	读取	减速度	30 (rps/s/s)	载入	读取
外部脉冲边沿触发选择	下降沿有效	载入	读取	启动Jog			

Control Mode	Description
Single Mode Pulse	Position control mode; the pulse type is pulse+direction
Dual mode pulse	Position control mode; the pulse type is CW/CCW pulse
Self-test Mode	Driver self-test mode; after setting, the motor will repeatedly rotate back and forth for 1 circle.

5.2.2 Current Setting

Modify the "Motor ID" according to the motor model used (**this is a necessary step**)

Step1:参数配置 Step2:电机控制整定 配置EtherCAT 电机位置状态 固件升级

1. 电机配置

电机型号: 电机ID:

细分旋钮: 地址旋钮:

默认方向: 正向 反向

脉冲模式: 单脉冲 双脉冲

电机默认参数设置

2. 控制模式设置

连续电流 (0.01-5A)

峰值电流 (0.5-7A)

开机扫描电流 (0.01-8.5A)

Motor ID	Adaptive motor	Current value
1	20 or 28 series motor	0.5A
3	42 series motor	1.5A
6	57 series motor (short type)	4A
8	57 series motor (long type)	4A
9	60 series motor	4A
C	86 series motor (short type)	6A
E	86 series motor (long type)	6A

*20... 86 refer to the flange size of the stepper motor.

Users can also refer to the current value on the motor nameplate to select the motor ID. For example, the rated current of the motor in the diagram below is 1.5A, and the motor ID is selected as 3.



Modifying the motor ID is equivalent to selecting the appropriate motor model, with each motor ID corresponding to a different preset current value.

If the preset current value of the driver does not match the actual application, the current parameters can be modified by the user. After selecting the motor ID, the user needs to customize the current parameters

Current setting method:

Motor ID	Select the appropriate motor ID (restart taking effect)
Default parameters setting of motor	<input type="checkbox"/> Enabling: The current is set by dialing; <input checked="" type="checkbox"/> disabling: current is set by software
Continuous current	The idle current of the motor is recommended to be set to 50% of the rated current of the motor
Peak current	The peak current for normal operation of the motor is recommended to be set to the rated current of the motor
Startup scanning current	It is the current used for phase finding when the motor is enabled. It is recommended to set it to the rated current of the motor

Example: Setting the current parameters of a motor with a rated current of 1.5A through software



5.2.3 Subdivision Setting

Subdivided electronic gear ratio: The number of pulses required for the motor to rotate one revolution; you can input any even numerical value between 200 and 51200.

Factory default value: 4000



5.2.4 Encoder Resolution Setting

Encoder electronic gear ratio: The number of pulses fed back by the encoder when the motor rotates one revolution.

Factory default value: 4000

Note: The value filled in here represents the encoder resolution rather than the number of encoder lines. Example: When a 1000-line encoder is used, the input value should be 4000; when a 2000-line encoder is used, the input value should be 8000; and so forth. Most of the Kaifull closed-loop motors are 1000-line encoders, and this parameter generally does not need to be modified.

2. 控制设置

编码器电子齿轮比	<input type="text" value="4000"/>	(200-51200)	<input type="button" value="载入"/>
细分电子齿轮比	<input type="text" value="4000"/>	(200-51200)	<input type="button" value="载入"/>
平滑滤波	<input type="text" value="100"/>	(1-1500)	<input type="button" value="载入"/>

5.3 Parameters Saving

After setting all parameters, click "One button download" to power off and save all parameters



Successful save prompt:

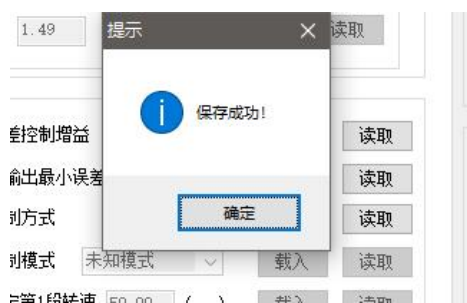

5.4 Saving/Opening Parameter File

Users can save the current parameters as a file for easy downloading to other drivers



5.5 Firmware Update

Select the files to be upgraded and click "Start"

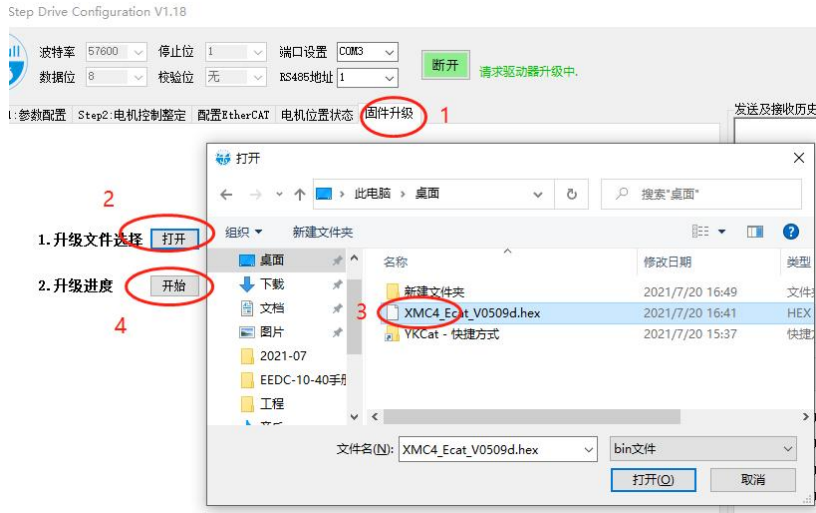

Waiting until the progress bar reaches 100%, which indicates that the update has been completed

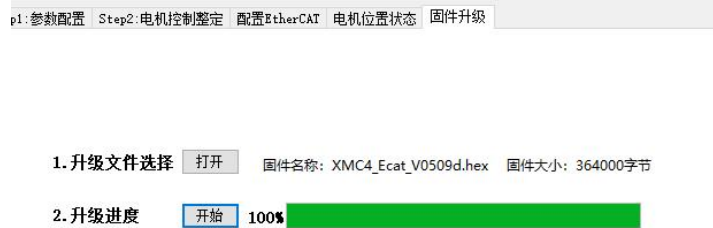

6 Alarm Code

The Y2SS3-S driver displays status and errors through a combination of flashing green and red LED indicator lights, with the specific meaning as follows:

LED indicator light	Meaning	Resolution
Green light normally on	Motor not enabled	-
Green light flashing	Motor enabled normally	-
4 red lights and 1 green light	Excessively high bus voltage	<ol style="list-style-type: none"> 1. Check whether the supply voltage of the driver is too high; 2. In case of overvoltage during movement, the motor deceleration time can be increased.
4 red LED lights and 2 green LED lights	Excessively low bus voltage	Check whether the supply voltage of the driver is too low;
5 red lights +1 green light	Motor overcurrent	<ol style="list-style-type: none"> 1. Check whether the motor has been damaged; 2. Check whether the set current of the driver is too high;
6 red lights +1 green light	Motor open circuit	<ol style="list-style-type: none"> 1. Check whether the motor wiring is correct; 2. Check whether the motor has been damaged
5 red LED lights and 2 green LED lights	Position deviation	<ol style="list-style-type: none"> 1. Check whether the encoder wire is connected correctly and securely 2. Check whether the encoder resolution is set correctly 3. Check whether the motor is blocked 4. Increase the acceleration and deceleration time appropriately